

Manufacturers of Custom Fluid Systems

Standard Hydraulic Power Unit (HPU)

Pascal Systems specializes in vertical power units

- From 1 hp singles to 500 hp multi-stations.
- These are not typical vertical power units.
- These are designed for extended life and serviceability.
- This design lends itself to quiet operation and a compact footprint.

The pictured unit is 30 hp and contained in a space of 33" wide x 37" deep and 54" tall.

- Environmentally Friendly

These units are considered "Zero-Leak" as there are no soft connections outside the reservoir.

Should fitting or pump seals begin to fail, all fluid is contained in the reservoir.

This is superior to traditional "Drip Pans" as fluid in drip pans is immediately contaminated and needs disposal.

The leaking fluid in this design is kept clean and in the reservoir.

The fluid remains "working fluid" and does not require disposal.

Unit Options

- Units can be built in any configuration ("L" style, Tank Top, etc)
- Remote or top mounted Pressure Compensation Control.
- Any flow or pressure range
- Pressure Filters, Control Valves, etc.

Fabrication:

Custom Name Plates. Custom name plates with your logo can be created

Quality Fabrication. Craftsman quality fabrication and assembly.

Testing. Units are tested prior to leaving our facility.

Value Added:

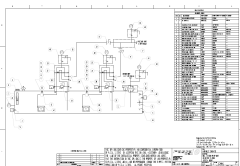

Manuals and Documentation. Pascal can provide custom manuals based on the system configuration

Component Cut Sheets and Spares List. Component cut sheets are provided as a single .pdf file.

Support and Troubleshooting. Pascal is available should problems occur.



Hydraulic Power Unit
O&M Manual

Top Access Cover
Pump Adjustment
Coupling

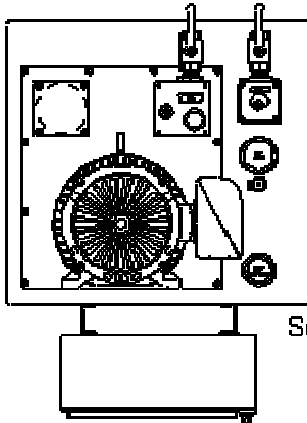

Vertical Manifold
Flows to 80 GPM
Check, Relief, Gauge

In-Tank Return Filter

High Flow
Air Filter

Sealed Filler Cap

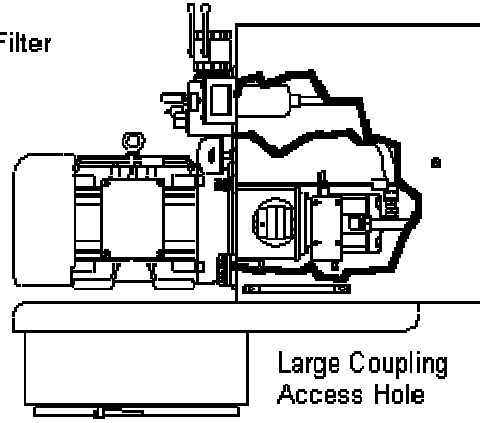

Large Coupling
Access Hole

Pump/Motor Set Mounting Plate
Remove Pump, Motor, Manifold, and
all Pressure Plumbing as a single unit
without disturbing the rest of the unit

Custom Electrical
Per your Specifications

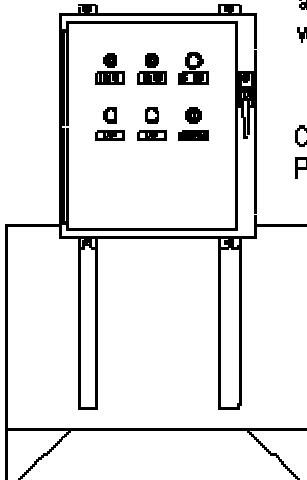

Reservoir
Pressure and Leak Tested
Interior Painted after Acid Etch
Painted Exterior Urethane Enamel



© Pascal Systems
2350 Del Monte Street
Phone (916)-372-5411 • Fax (916)-373-0952 •